



Acoustic Cleaning Systems

P.O. Box 609, Alexandria, AL 36250

Phone: 256-820-8427 FAX: 256-820-6570

**Operation and Maintenance
Manual for Models AC-220, AC-230,
ESP-75, AC-75, and AC-75C**



Dear Customer:

Thank you for choosing the finest quality acoustic cleaning system on the market today. ACS acoustic cleaners are a proven method for cleaning or dislodging dry particulate or product in a variety of applications. Since the principal of operation is simple the acoustic cleaners offer a highly effective low cost alternative to other cleaning methods.

By reviewing your application requirements, we have recommended the most effective unit along with the proper installation method. Based on this information, it is important that these installation procedures are followed.

We have also made every effort to insure that this manual is as complete and concise as possible, but it seems as though something always gets left out inadvertently. In this case if you have any questions about an installation, please feel free to give us a call. We will be happy to assist you with any questions or concerns that you may have.

Best Regards,

Acoustic Cleaning Systems, Inc.

Table of Contents

<i>Section 1:</i>	Introduction	4
<i>Section 2:</i>	Horn Specifications	5
<i>Section 3:</i>	Applications	16
<i>Section 4:</i>	General Installation Notes	21
<i>Section 5:</i>	ACS Installation Illustrations	22
<i>Section 6:</i>	ACS Piping Installation Diagram	30
<i>Section 7:</i>	Solenoid Valves	31
<i>Section 8:</i>	Controls	31
<i>Section 9:</i>	Repair and Service	32
<i>Section 10:</i>	Maintenance	32
<i>Section 11:</i>	General Troubleshooting Diagrams	33
<i>Section 12:</i>	Frequently Asked Questions	35
<i>Section 13:</i>	Safety Precautions	36

Section 1: Introduction

Acoustic cleaners have been utilized for cleaning particulate matter as well as dry product buildup in many applications for a number of years. Some of the applications include SCR's, boilers, ESP's, baghouses, ID fans and material handling applications. Today, acoustic cleaners are a proven, effective and cost efficient way to remove unwanted buildup without causing any structural damage.

The cleaners manufactured by ACS are pneumatically operated horns that produce a low frequency high-energy sound wave. The sound wave is produced when the titanium diaphragm is flexed by introducing compressed air into the sound generator. When the pressure equalizes, the diaphragm flexes back over the pedestal orifice and creates a sound wave. The acoustic cleaner's bell amplifies this resulting sound wave.

The sound wave produced generates energy to resonate and dislodge material buildup from surfaces. The resonating effect is similar to striking the surface with a hammer; however, with acoustic energy you do not get a destructive effect. Once the material is dislodged gas flow and /or gravity remove it from the surfaces to which it clings.

By utilizing acoustic horns, operational costs as well as maintenance costs can be reduced significantly. The operational cost is decreased because equipment downtime is minimized.

Proper horn sizing and installation placement play a role in the success of horns, but in many cases it is not an exact science. We would like to suggest that the recommendations in this manual be followed whenever possible. In the event you have an obstruction or questions concerning installations, please do not hesitate to contact us.

Section 2: Horn Specifications

1. Model AC-220

- A. *AC-941*: AC-220 powder coated cast iron bell with a zinc plated sound generator.
- B. *AC-946*: AC-220 cast stainless steel bell with a zinc plated sound generator.

2. Model AC-230

- A. *AC-939*: AC-230 powder coated cast iron A and B sections with a zinc plated sound generator.
- B. *AC-942*: AC-230 powder coated cast iron A section and cast stainless steel B section with a zinc plated sound generator.
- C. *AC-948*: AC-230 cast stainless steel A and B sections with a zinc plated sound generator.

3. Model ESP-75

- A. *AC-943*: ESP-75 powder coated cast iron A and B sections and powder coated fabricated carbon steel C section with a zinc plated sound generator

4. Model AC-75 and AC-75C

- A. *AC-959*: AC-75C powder coated cast iron A section, powder coated cast ductile iron B section, and fabricated carbon steel C section with a zinc plated sound generator.
- B. *AC-907*: AC-75 powder coated cast iron A and B section and fabricated stainless steel C section with a zinc plated sound generator.
- C. *AC-938*: AC-75C powder coated cast iron A section, powder coated cast ductile ironl curved B section, and fabricated stainless steel C section with a zinc plated sound generator.
- D. *AC-969*: AC-75 powder coated cast iron A and B sections and fabricated carbon steel C section with a zinc plated sound generator.

All horns can be mounted in a variety of ways, which will be discussed in Section 4 of this manual. Custom installations can also be designed and fabricated when required.

Model AC-220

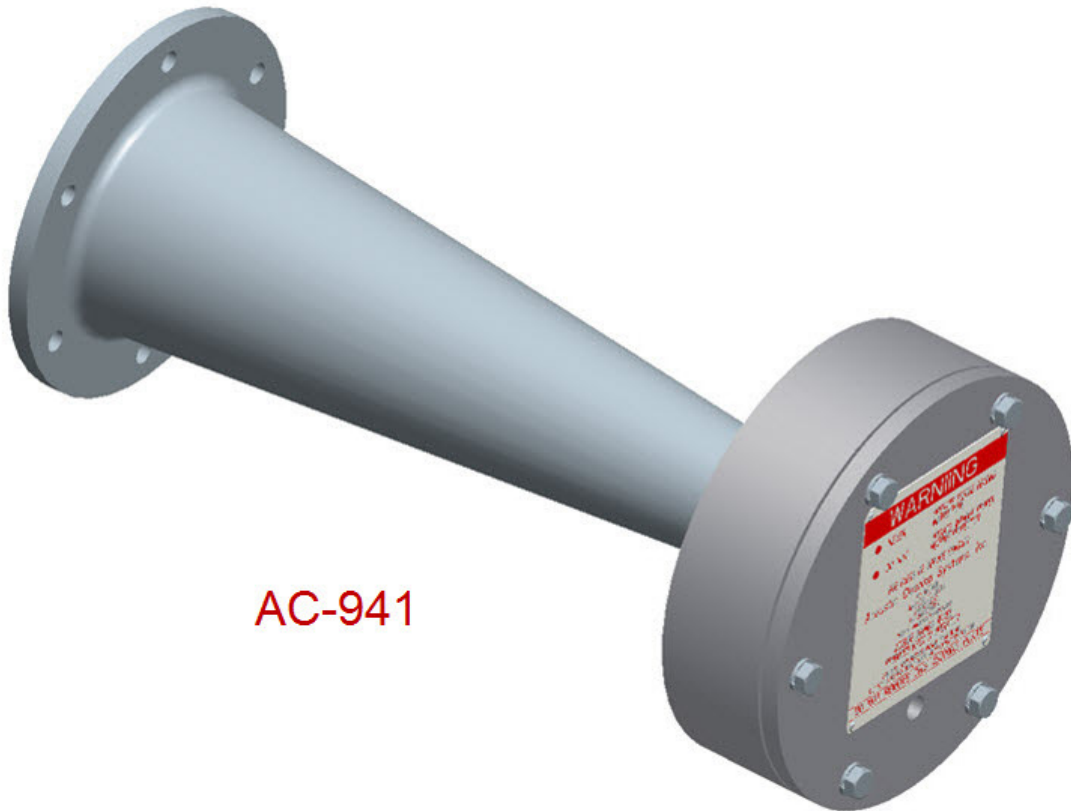

AC-941

Part No. as shown: AC-941

Fundamental Frequency: 220 Hz

Output Power: 150 dB @ 1 Meter from bell

Material of Construction:

Bell: Powder Coated Cast Iron

Sound Generator: Zinc plated cast iron

Weight: 35lbs without mounting hardware

Length: Overall length 16.43"

Air Consumption: 80 SCFM @ 80 PSI

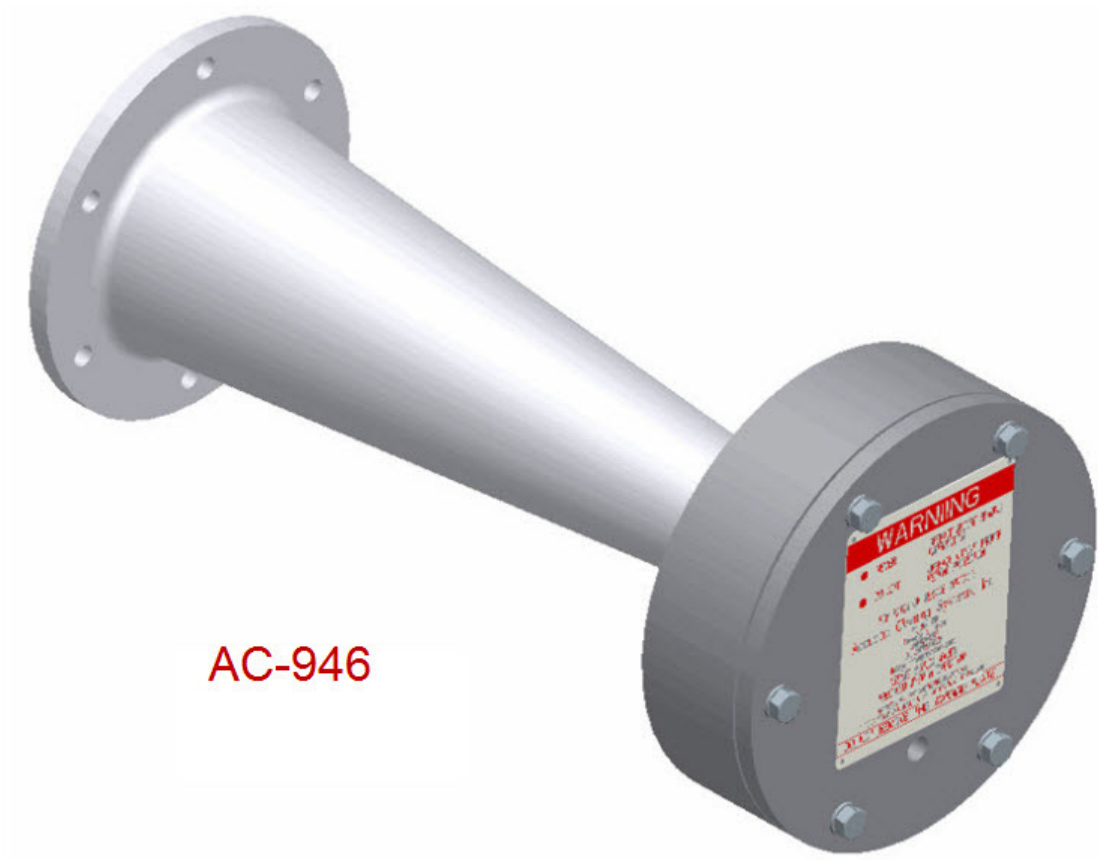

AC-946

Part No. as shown: AC-946

Fundamental Frequency: 220 Hz

Output Power: 150 dB @ 1 Meter from bell

Material of Construction:

Bell: Cast stainless steel

Sound Generator: Zinc plated cast iron

Weight: 34.5lbs without mounting hardware

Length: Overall length 16.43”

Air Consumption: 80 SCFM @ 80 PSI

Model AC-230



AC-939

Part No. as shown: AC-939

Fundamental Frequency: 230 Hz

Output Power: 150 dB @ 1 Meter from bell

Material of Construction:

Bell Section A: Powder Coated Cast Iron

Bell Section B: Powder Coated Cast Iron

Sound Generator: Zinc plated cast iron

Weight: 57lbs without mounting hardware

Length: Overall length 26.8”

Air Consumption: 80 SCFM @ 80 PSI

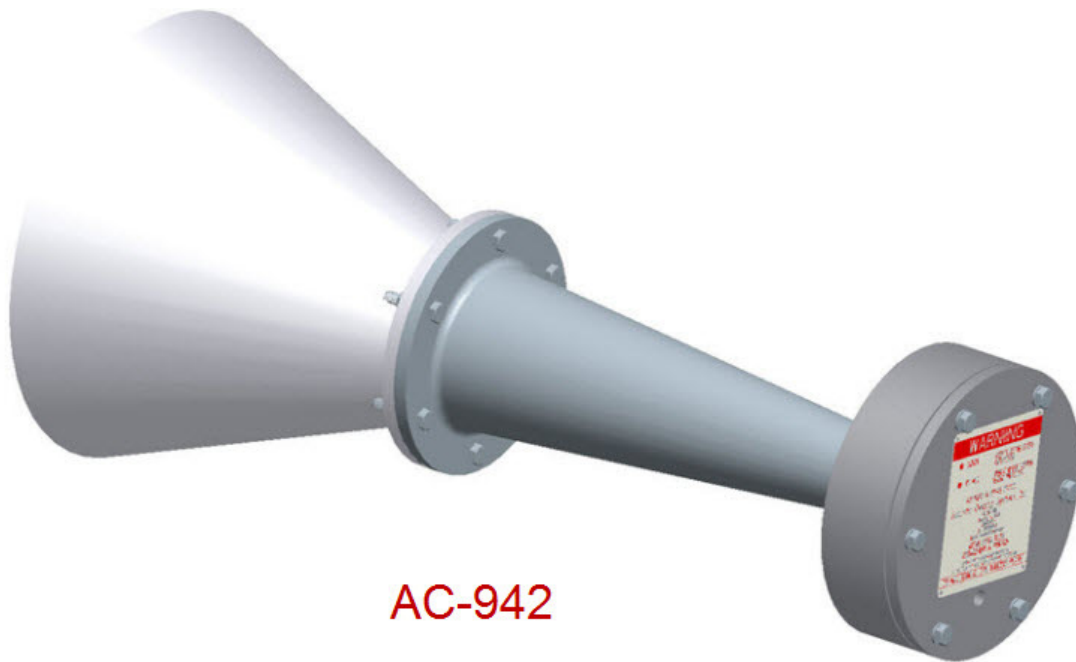

AC-942

Fundamental Frequency: 230 Hz

Output Power: 150 dB @ 1 Meter from bell

Material of Construction:

Bell Section A: Powder Coated Cast Iron

Bell Section B: Cast stainless steel

Sound Generator: Zinc plated cast iron

Weight: 57lbs without mounting hardware

Length: Overall length 26.8”

Air Consumption: 80 SCFM @ 80 PSI

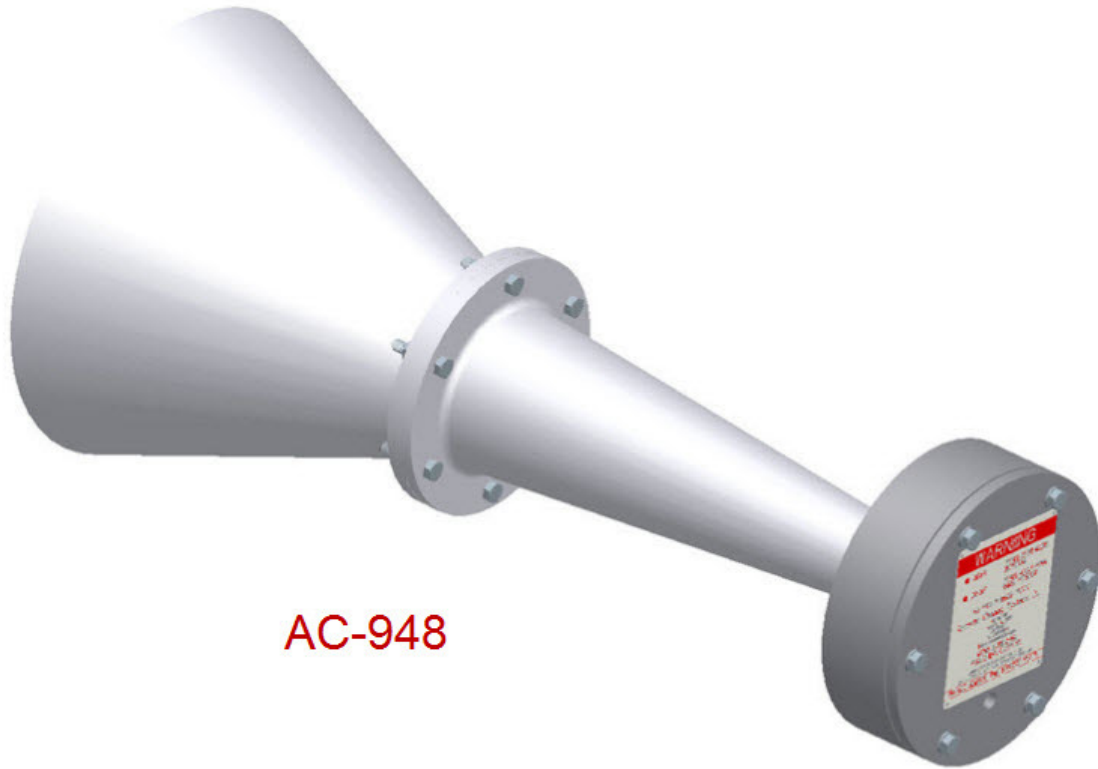

AC-948

Fundamental Frequency: 230 Hz

Output Power: 150 dB @ 1 Meter from bell

Material of Construction:

Bell Section A: Cast stainless steel

Bell Section B: Cast stainless steel

Sound Generator: Zinc plated cast iron

Weight: 56.5lbs without mounting hardware

Length: Overall length 26.8”

Air Consumption: 80 SCFM @ 80 PSI

Model ESP-75

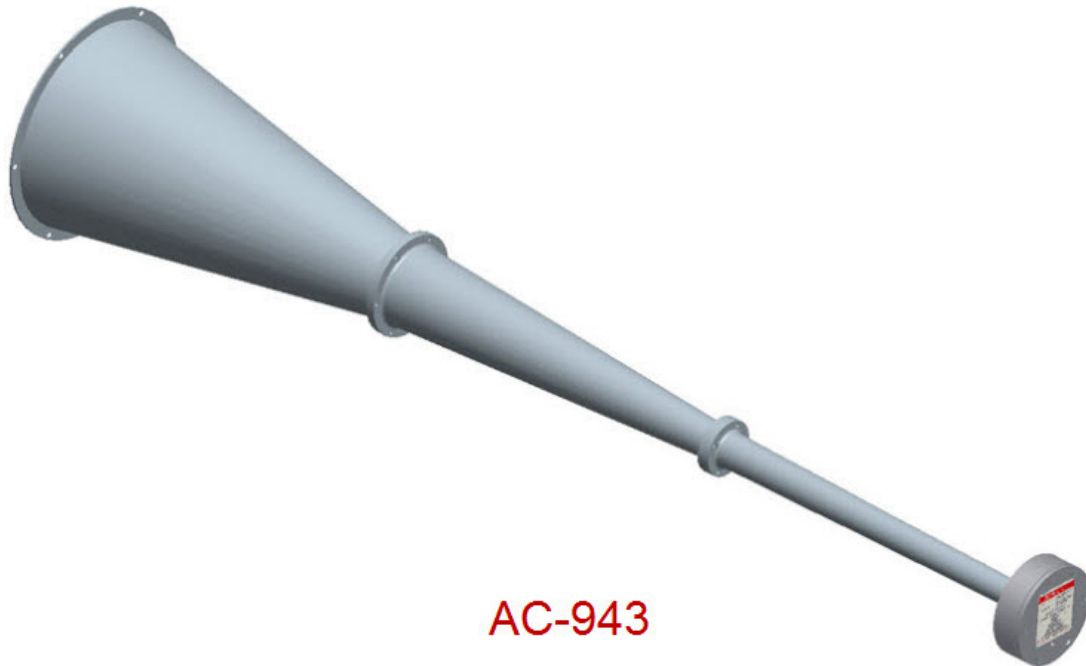

AC-943

Fundamental Frequency: 75 Hz

Output Power: 147 dB

Material of Construction:

Bell Section A: Powder coated cast iron

Bell Section B: Powder coated cast iron

Bell Section C: Powder coated fabricated carbon steel with flange

Sound Generator: Zinc plated cast iron

Weight: 117.5lbs without mounting hardware

Length: Overall length 91.78”

Air Consumption: 80 SCFM @ 80 PSI

Model AC-75

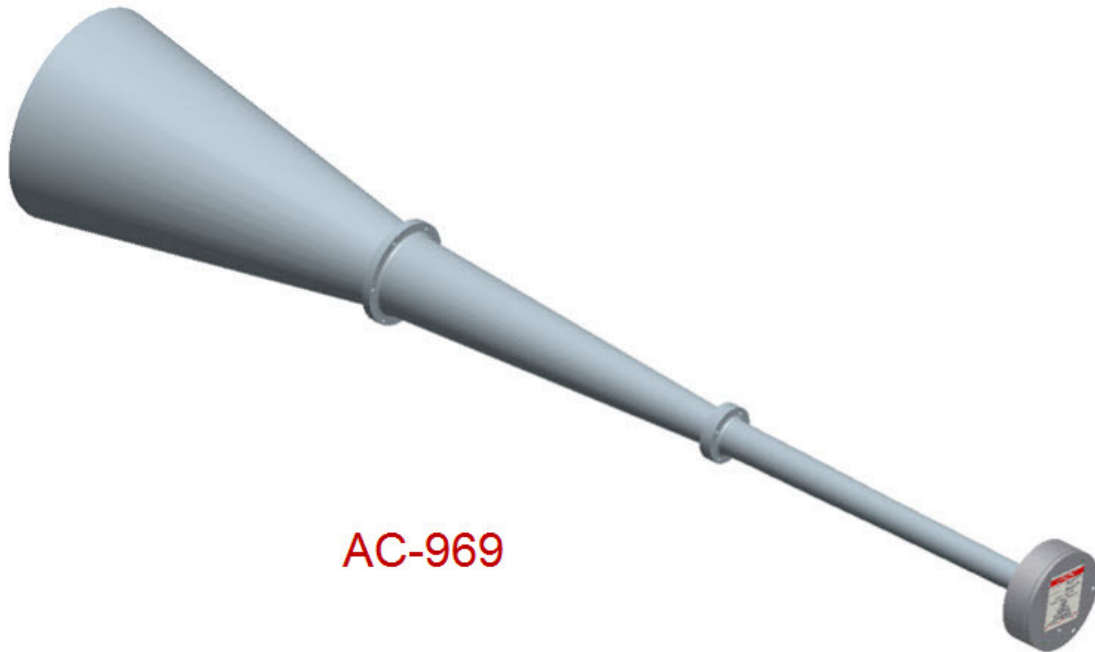

Fundamental Frequency: 75 Hz

Output Power: 147 dB

Material of Construction:

Bell Section A: Powder coated cast iron

Bell Section B: Powder coated cast iron

Bell Section C: Powder Coated fabricated carbon steel

Sound Generator: Zinc plated cast iron

Weight: 116.5lbs without mounting hardware

Length: Overall length 91.78"

Air Consumption: 80 SCFM @ 80 PSI

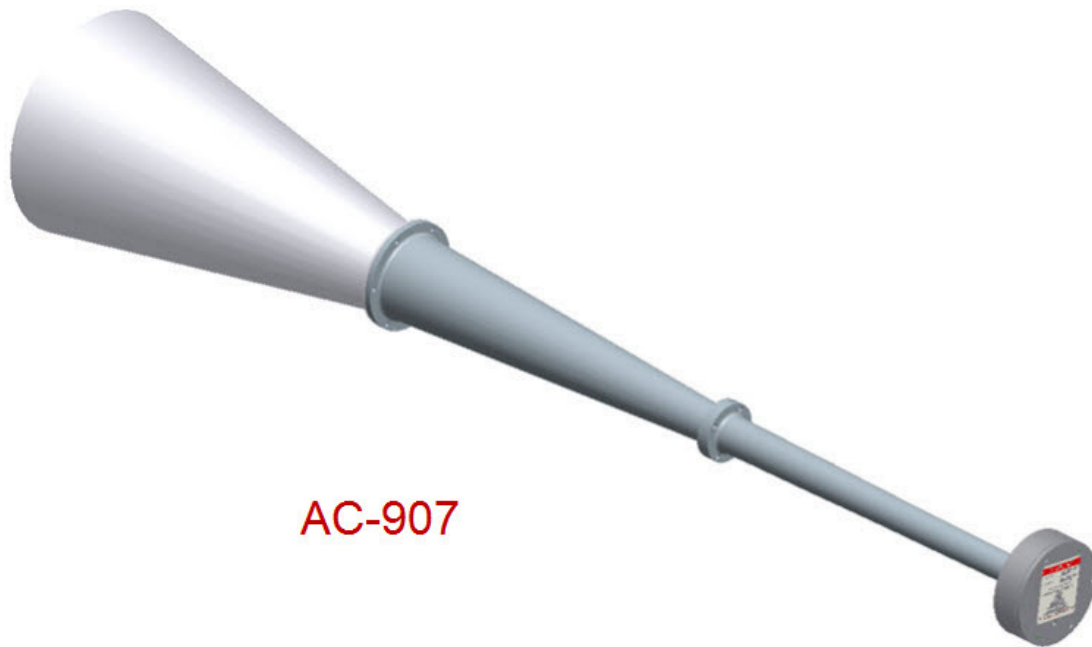

AC-907

Fundamental Frequency: 75 Hz

Output Power: 147 dB

Material of Construction:

Bell Section A: Powder coated cast iron

Bell Section B: Powder coated cast iron

Bell Section C: Fabricated stainless steel

Sound Generator: Zinc plated cast iron

Weight: 117.5lbs without mounting hardware

Length: Overall length 91.78"

Air Consumption: 80 SCFM @ 80 PSI

Model AC-75C



Fundamental Frequency: 75 Hz

Output Power: 147 dB

Material of Construction:

Bell Section A: Powder coated cast iron
Bell Section B: Powder coated cast ductile iron (curved)
Bell Section C: Fabricated stainless steel
Sound Generator: Zinc plated cast iron

Weight: 123lbs without mounting hardware

Length: Distance for end of cover plate to the centerline of the C section is 45.3125", Distance from the center line of the A section to the end of the c section is 46.00"

Air Consumption: 80 SCFM @ 80 PSI



Fundamental Frequency: 75 Hz

Output Power: 147 dB

Material of Construction:

Bell Section A: Powder coated cast iron
Bell Section B: Powder coated cast ductile iron (curved)
Bell Section C: Fabricated stainless steel
Sound Generator: Zinc plated cast iron

Weight: 123lbs without mounting hardware

Length: Distance for end of cover plate to the centerline of the C section is 45.3125", Distance from the center line of the A section to the end of the c section is 46.00"

Air Consumption: 80 SCFM @ 80 PSI

Section 3: Applications

SCR's

Objective

Sonic horns are a proven means and the most widely used cleaning method for SCR reactors. They are used to keep the ash buildup from occurring on the catalyst beds. The initial cost savings along with the operational cost savings far outweigh alternative cleaning methods.

SCR horns are typically operated fairly aggressively in order to keep excessive amounts of buildup from occurring. It is also important to insulate the bell sections and to operate the horns year around to eliminate the potential of condensation taking place and plugging the bell.

Horn Location

It is very important to locate horns in an SCR reactor based on platform location and the relationship of the horn to the catalyst layers. The type design of the SCR also plays a role on the recommendation for locating the horns.

Installation

A typical installation for an SCR is to utilize a mounting ring and flange for mounting the horn to the face of the reactor. The C section of the horn is typically inserted into the reactor and the sound generator and A & B sections are external to the reactor.

Both straight and curved design horns have been utilized successfully on SCR reactors. Curved units are typically used when space limitations occur due to the lack of platform width.

Horn spacing on an SCR is more critical in the corners than in the middle of the reactor. If the spacing has to grow it should grow in the middle of the reactor and the horns should be spaced more closely toward the corners. ACS will make a recommendation on proper spacing of the horns for each project.

In all cases it should be seriously considered to insulate the bell sections external to the reactor to prevent condensation inside the bell. This condensation promotes the potential for ash buildup to occur. Another recommendation is to operate the horns year around, even if you are not required to do so in order to eliminate potential problems when starting them back up for the next ozone season.

While only the normal installation has been discussed here there are variations for mounting such as a mounting tube and two bell insertion methods. ACS is committed to the customer and custom mounting options for any situation can be designed to suit all of your needs.

Start-up

The following should be reviewed prior to start-up:

1. **Air Piping**-Correct air pressure and flow is important to the operation of the horns and the system should be reviewed prior to start-up.
2. **Air Pressure**- It is important to make sure that the horns are getting the recommended 70-90psi. The horns will sound at much lower pressures than recommended, but they operate most effectively at the recommended pressure ranges.
3. **Verifying Operation**-If the solenoid valve was supplied by ACS it will have a manual override. Use the override to listen to each horn to insure the horn is sounding as it should. You will feel a resonance in your body and clothes and the horn will produce a low tone much like a foghorn on a ship.
4. **Verifying Sequence**-Horns are not operated on a continuous cycle therefore the cycling of the horns should be confirmed to make sure the operating duration and sequence is correct. If they are not correct, they can be corrected at that time before commissioning the system. In an SCR application the horns are sounded for 10 seconds every 10 minutes. It is also possible to operate more than 1 horn at a time, but in most cases this is not necessary.

Boilers

Objective

ACS horns are proven and effective in cleaning heat transfer surfaces in many boiler applications. These include super heaters, generating banks, air heaters, and economizer sections. They can be used to supplement existing steam sootblowers and in some cases eliminate the requirement for the plant to operate their steam sootblowers. By cleaning more frequently with horns the elimination of opacity spikes have also been discovered. In most boiler applications the horns can be operated very aggressively, therefore keeping the heat transfer surfaces cleaner between sootblower cycles.

Horn Locations

In most cases boilers are manufactured with access between tube sections. Typically access doors are placed in these regions and horns are mounted in these locations. It is important to know the wall thickness in order for the proper recommendation to be made. If there are any exterior obstructions these would need to be considered when a mounting recommendation is made.

It is important to know the temperature reading in the region that the horns are to be installed. This has a twofold purpose 1) It enables the operators to know the effectiveness of the horns in a given region of the boiler 2) Gives us the knowledge we need to make proper material recommendation for the horns.

While only the normal installation has been discussed here there are variations for mounting such as using the existing soot blower openings. ACS is committed to the customer and custom mounting options for any situation can be designed to suit all of your needs.

Start-up

The following should be reviewed prior to start-up:

1. **Air Piping**-Correct air pressure and flow is important to the operation of the horns and the system should be reviewed prior to start-up.
2. **Air Pressure**- It is important to make sure that the horns are getting the recommended 70-90psi. The horns will sound at much lower pressures than recommended, but they operate most effectively at the recommended pressure ranges.
3. **Verifying Operation**-If the solenoid valve was supplied by ACS it will have a manual override. Use the override to listen to each horn to insure the horn is sounding as it should. You will feel a resonance in your body and clothes and the horn will produce a low tone much like a foghorn on a ship.
4. **Verifying Sequence**-Horns are not operated on a continuous cycle therefore the cycling of the horns should be confirmed to make sure the operating duration and sequence is correct. If they are not correct, they can be corrected at that time before commissioning the system. In a boiler application the horns are sounded for 10 seconds every 10 minutes and can be adjusted based on what customer wants to achieve.

ESP's

Horns have been utilized on ESP's to supplement existing rapping systems and in some cases have completely eliminated the need to operate rappers. The horns have a much lower operational cost and are less to maintain than a conventional rapping system. Sonic horns also introduce less stress and fatigue to the plates and ESP themselves.

Guidelines to Follow:

- Do not operate 2 horns in the same casing at the same time.
- Horns in the first field of a precipitator are operated more frequently and for longer durations. Typically for 4-8 seconds every 8-12 minutes.
- Horns in the second field are operated 3-6 seconds every 8-12 minutes.
- When horns are started up in an ESP application it is common to see opacity spikes, but these will reduce as the precipitator and the internals become cleaner.

The procedure of fine tuning the sounding sequence for the horns varies depending on a number of conditions. The varying sources of coal have differing ash characteristics. Sulfur content, resistivity of the ash, gas temperature, and dust loading all affect the operation of the precipitator. All of these parameters will also affect the sequencing of the horns, therefore the following should be considered when fine tuning the horns in an ESP application:

- 1) The operating cycle should be set more aggressively in the inlet field because more of the ash is being collected there. The outlet fields operating cycle would be less based on the fact that the latter fields do less of the collecting. Over cycling can cause re-entrainment problems while under cycling can reduce electrical efficiency.
- 2) Sufficient time should be allowed between changes to the operating sequence in order to allow the system to stabilize and therefore yield a more accurate evaluation. 2-3 days of observation is recommended before any changes are to be made.
- 3) Make certain that the opacity monitor is operating correctly.

Baghouses

Objective

It is important to maintain primary dustcake in baghouse applications. This will insure that bleedthrough and emissions are less likely to occur while prolonging bag life.

Depth Filtration

When using conventional woven fabric, filtering occurs as a result of primary dustcake forming on the bag surface. This dustcake provides a collection surface preventing smaller particles from becoming trapped in the weave. In time this embedded particulate would abrade the fibers and weaken the bag especially at the higher stress locations. If this dustcake is not present it will allow these particles to embed and plug the bag surface creating a high differential pressure situation. These embedded particles cannot be cleaned by typical cleaning cycles.

If bags have a PTFE membrane this dustcake is not required. The Teflon coating allows for easy release of the cake during an acoustic cleaning cycle.

Proper Start-up Procedures

Baghouse fans are designed to overcome the resistance across the ductwork and the bags. Considering new bags do not provide this resistance at first, it is important dampen the fan resulting in decreased velocities across the bag's surface. If you have high velocities the initial particles can be driven into the bag surface. A pre-coating is available to help build this primary dustcake to a permeable state. The cleaning cycle should not be initiated until the dustcake has formed on the surface of the bag. This is critical to the life of the bags.

Cleaning Procedures

Excessive cleaning can be avoided by programming the baghouse to clean on demand or when the differential pressure exceeds a predetermined value. This is typically 3-6" of differential pressure. This will vary however, based on operating conditions.

Start-up Procedure

The correct start-up will play a major role in maximizing your system.

- 1) Turn off the cleaning cycle
- 2) Open the damper to the system
- 3) Open the outlet damper to 10%. This will eliminate high velocities in the collector.
- 4) Precoat material should be introduced as soon as the outlet damper is opened.
- 5) Following the precoat the outlet damper should be opened slowly.
- 6) Monitor differential pressure at both flanges and at the tubesheet and initiate cleaning cycle once 3-6" of resistance is obtained.

Cleaning Cycle

Once the compartment for cleaning is isolated, the manometer reading should be zero. Once at zero this means the compartment is isolated from flow.

Acoustic cleaning is initiated during the reverse air or shaking cycle. The horns will operate 10-30 seconds at the same time the reverse air dampers open.

The acoustic energy generated during this cycle will break the bond of the particulate and gravity will carry particles into the hopper. If the compartment is not completely isolated this will create a backflow and particles will be suspended and allowed to accumulate on the bags surface. This in turn will cause restricted airflow and elevated differential pressure.

Typical Cleaning Sequence:

- 1) Front end null period of 10 seconds. This allows enough time for the isolation damper to close.
- 2) Actuate the horns for 10-30 seconds during the reverse air or shaking cycle.
- 3) Back end null of 30 seconds so fine particles can make it to hopper.
- 4) Bring compartment back in service.
- 5) Initiate cycle in next compartment.

Section 4: General Installation Notes

When installing acoustic horns it is very important not to direct the end of the bell upward as this could cause buildup within the bell itself. It is recommended that the units be mounted either horizontally or in a downward fashion. It is also important to note that when utilizing a curved unit, the horn should be mounted in a fashion that it would be mounted from the 9:00 to 3:00 position. In other words the sound generator on a curved horn installation should never be mounted below horizontal.

Horns can be mounted in several different configurations as shown below. The methods most commonly used would be installed using standard mounting hardware. In the event standard hardware cannot be used, ACS will work with the customer to work out the best arrangement even if it requires custom mounting hardware.

Very Important!!

Once a horn is installed it should be placed into service as soon as possible. An idle horn is subject to the buildup problems it has been designed to remove and by putting it into operation it will potentially eliminate this from occurring.

Section 5: ACS Installation Illustrations

The following show the most common mounting options for all models of ACS horns. Although these mounting arrangements are most commonly used, custom designed mounting solutions are available for any specific application.

AC-220 Mounting Ring Installation

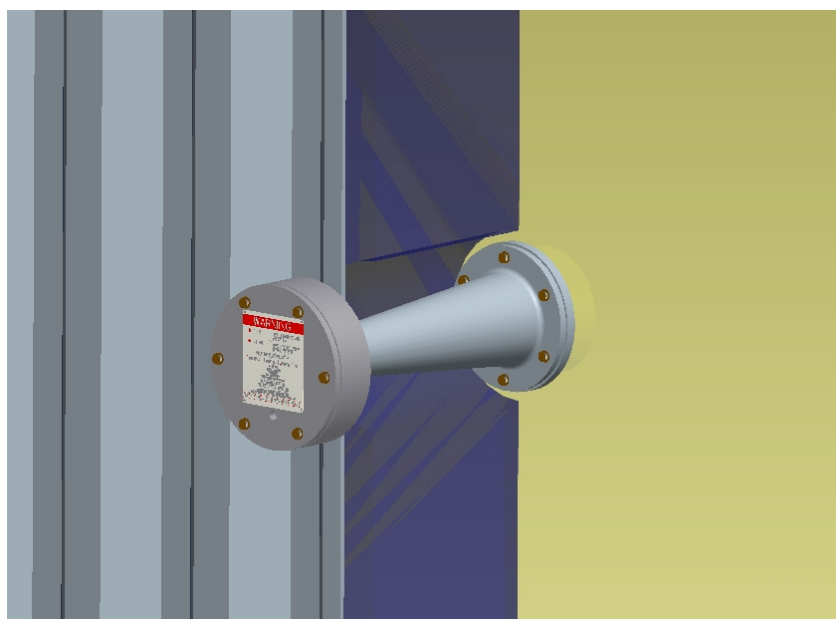

1. Cut a 3.75" diameter opening in application surface.
2. Place the mounting ring in the proper location as shown in the picture and tack weld in place. The mounting ring should be placed on the mounting surface with holes located in the 12 and 6 o'clock positions. This hole location will ensure the inlet to the horn is in the 6 o'clock position when the horn is mounted on a vertical surface.
3. Attach the horn to mounting ring with (6) 5/16-18 x 3/4" hex head cap-screws.
4. Seal weld the remainder of mounting ring to the application surface.
5. Connect the air supply from the solenoid valve to the sound generator.

AC-230 Mounting Ring and Flange Installation

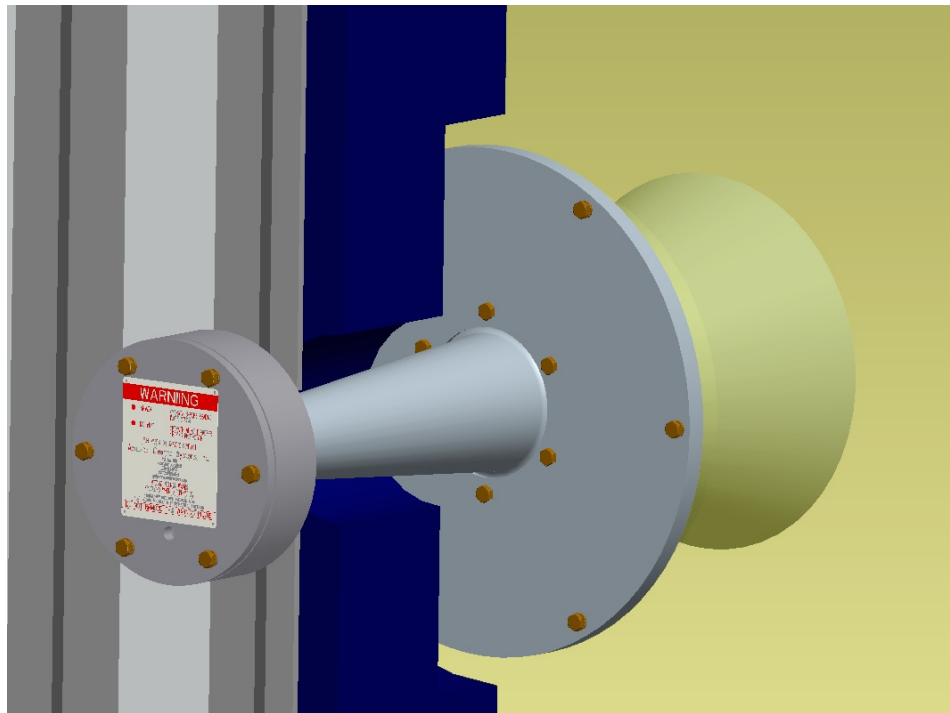

1. Cut a 14” diameter opening in the application surface.
2. Place the mounting ring in the proper location as shown in the picture and tack weld in place. The mounting ring should be placed on the mounting surface with holes located in the 3 and 9 o’clock positions. This hole location will ensure the inlet to the horn is in the 6 o’clock position when the horn is mounted on a vertical surface.
3. Assemble the A sect., mounting flange, and B sect. together with 5/16-18 x 1.5” hex head cap-screws lock washers, and nuts.
4. Attach the mounting flange to the mounting ring with 5/16-18 x ¾” hex head cap-screws lock washers, and nuts.
5. Seal weld the remainder of mounting ring to the application surface.
6. Connect the air supply from the solenoid valve to the sound generator.

AC-230 Mounting Tube Installation

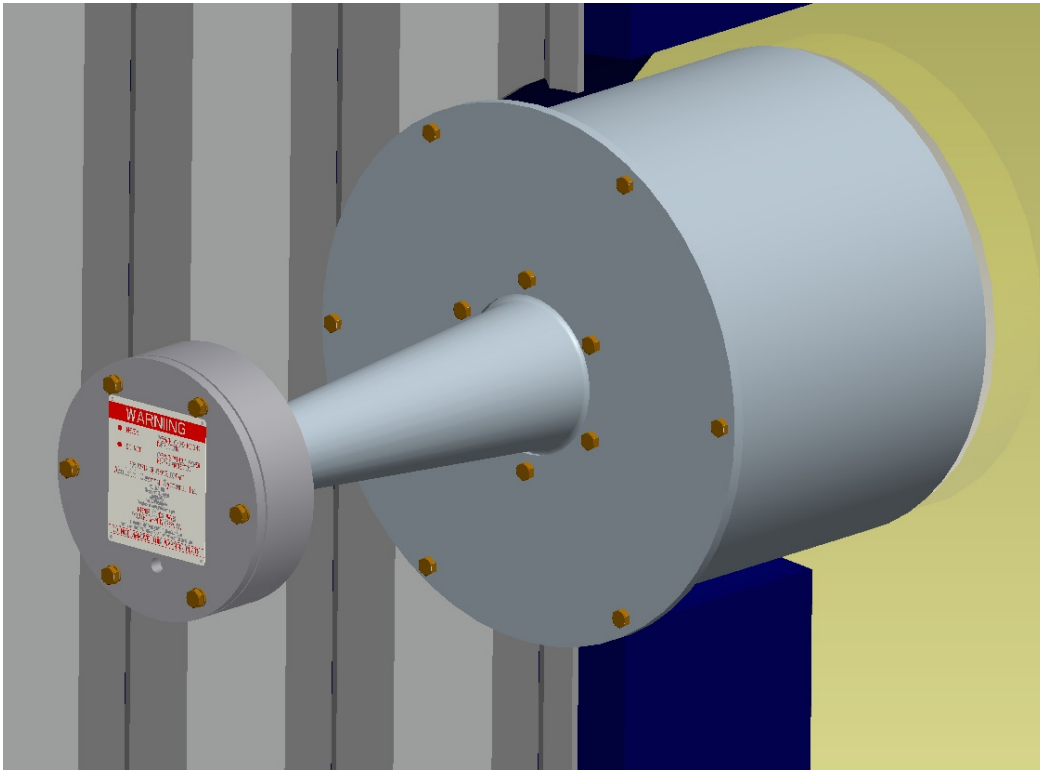

1. Cut a 14” diameter opening in the application surface.
2. Place the mounting tube in the proper location as shown in the picture and tack weld in place. The mounting tube should be placed on the mounting surface with holes located in the 3 and 9 o’clock positions. This hole location will ensure the inlet to the horn is in the 6 o’clock position when the horn is mounted on a vertical surface.
3. Assemble the A sect., mounting flange, and B sect together with 5/16-18 x 1.5” hex head cap-screws, lock washers, and nuts.
4. Attach the mounting flange to the mounting tube with 5/16-18 x 1” hex head cap-screws, lock washers, and nuts.
5. Seal weld the remainder of mounting tube to the application surface.
6. Connect the air supply from the solenoid valve to the sound generator.

AC-75 ESP Mounting Ring Installation

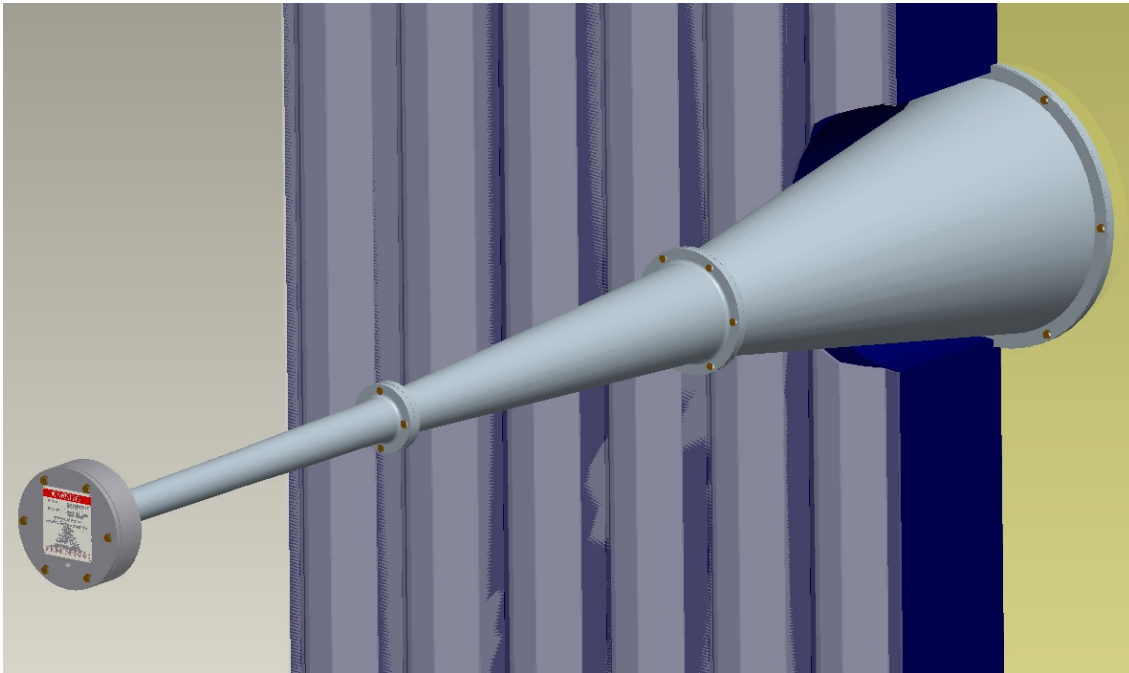

1. Cut a 15.75" diameter opening in the application surface.
2. Place the mounting ring in the proper location as shown in the picture and tack weld in place. The mounting ring should be placed on the mounting surface with holes located in the 3 and 9 o'clock positions. This hole location will ensure the inlet to the horn is in the 6 o'clock position when the horn is mounted on a vertical surface.
3. Assemble the A sect., B sect., and C sect. together with 5/16-18 x 1.5" hex head cap-screws, lock washers, and nuts.
4. Attach the C sect. flange to the mounting ring with 5/16-18 x 3/4" hex head cap-screws.
5. Seal weld the remainder of mounting ring to the application surface.
6. Connect the air supply from the solenoid valve to the sound generator.

AC-75 Mounting Ring and Flange Installation

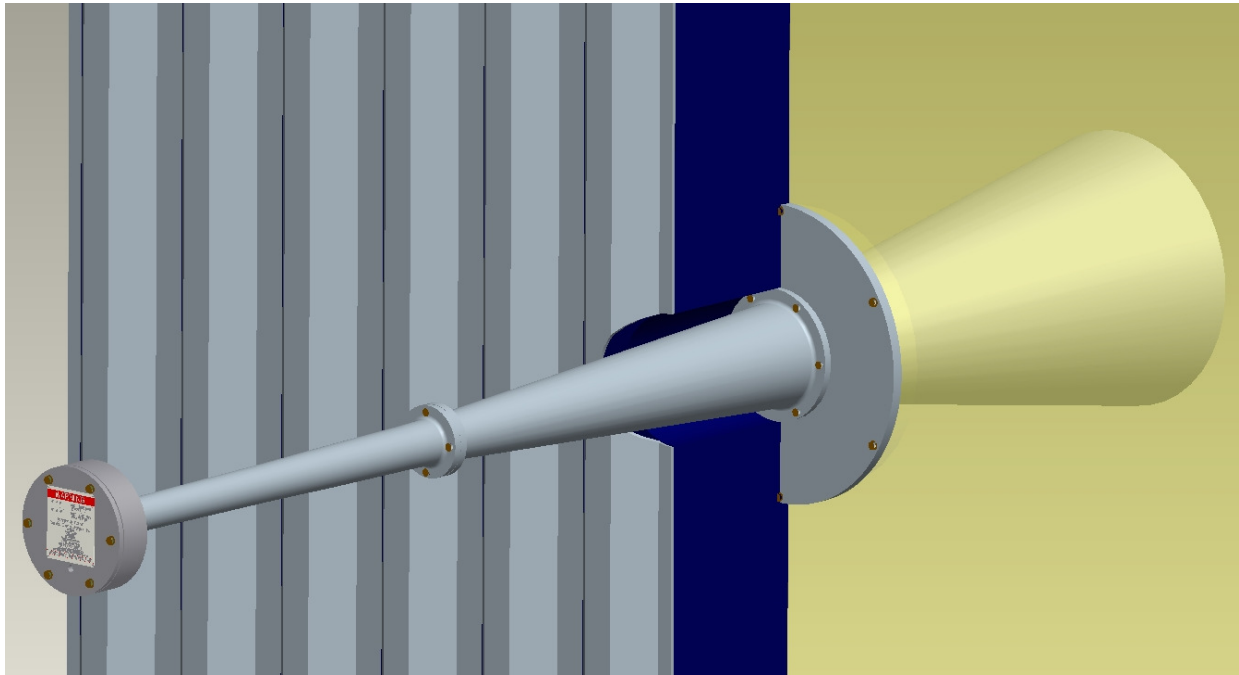

1. Cut a 16.25" diameter opening in the application surface.
2. Place the mounting ring in the proper location as shown in the picture and tack weld in place. The mounting ring should be placed on the mounting surface with holes located in the 12 and 6 o'clock positions. This hole location will ensure the inlet to the horn is in the 6 o'clock position when the horn is mounted on a vertical surface.
3. Assemble the B sect., C sect., and mounting flange together with 5/16-18 x 1.5" hex head cap-screws lock washers, and nuts.
4. Attach the mounting flange to the mounting ring with 5/16-18 x .75" hex head cap-screws lock washers, and nuts.
5. Seal weld the remainder of mounting ring to the application surface.
6. Attach the A sect. and sound generator to the B sect. with 5/16-18 x 1.5" hex head cap-screws lock washers, and nuts.
7. Connect the air supply from the solenoid valve to the sound generator.

AC-75 Mounting Tube Installation

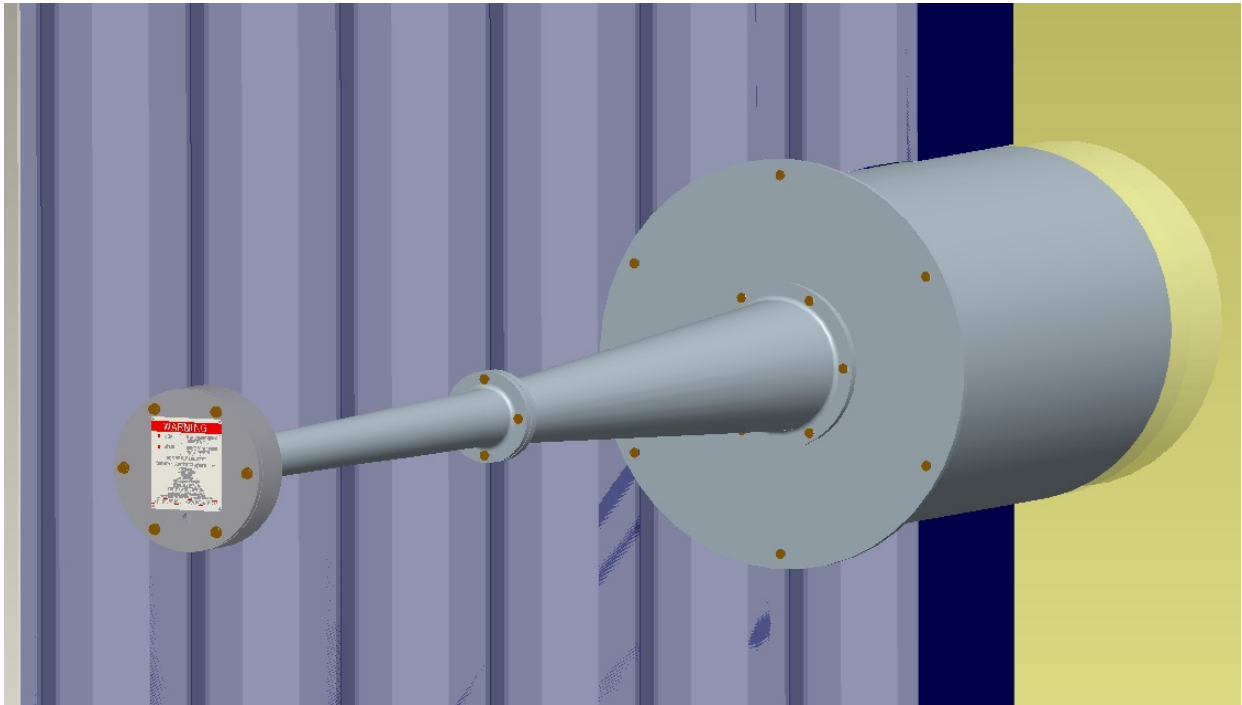

1. Cut a 16.25” diameter opening in the application surface.
2. Place the mounting tube in the proper location as shown in the picture and tack weld in place. The mounting ring should be placed on the mounting surface with holes located in the 12 and 6 o’clock positions. This hole location will ensure the inlet to the horn is in the 6 o’clock position when the horn is mounted on a vertical surface.
3. Assemble the B sect., C sect., and mounting flange together with 5/16-18 x 1.5” hex head cap-screws lock washers, and nuts.
4. Attach the mounting flange to the mounting tube with 5/16-18 x 1” hex head cap-screws lock washers, and nuts.
5. Seal weld the remainder of mounting tube to the application surface.
6. Attach the A sect. and sound generator to the B sect. with 5/16-18 x 1.5” hex head cap-screws lock washers, and nuts.
7. Connect the air supply from the solenoid valve to the sound generator.

AC-75C Mounting Ring and Flange Installation

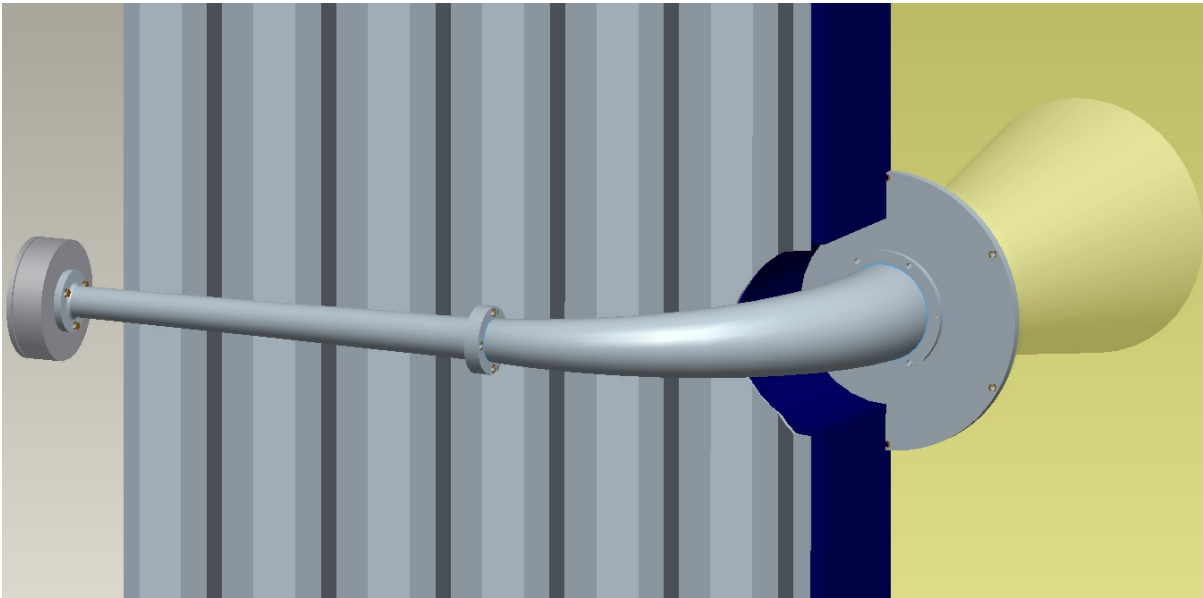

1. Cut a 16.25” diameter opening in the application surface.
2. Place the mounting ring in the proper location as shown in the picture and tack weld in place. The mounting ring should be placed on the mounting surface with holes located in the 12 and 6 o’clock positions. This hole location will ensure the inlet to the horn is in the 6 o’clock position when the horn is mounted on a vertical surface.
3. Assemble the B sect., C sect., and mounting flange together with 5/16-18 x 1.5” hex head cap-screws lock washers, and nuts.
4. Attach the mounting flange to the mounting ring with 5/16-18 x .75” hex head cap-screws lock washers, and nuts.
5. Seal weld the remainder of mounting ring to the application surface.
6. Attach the A sect. and sound generator to the B sect. with 5/16-18 x 1.5” hex head cap-screws lock washers, and nuts.
7. Connect the air supply from the solenoid valve to the sound generator.

AC-75C Mounting Tube and Flange Installation

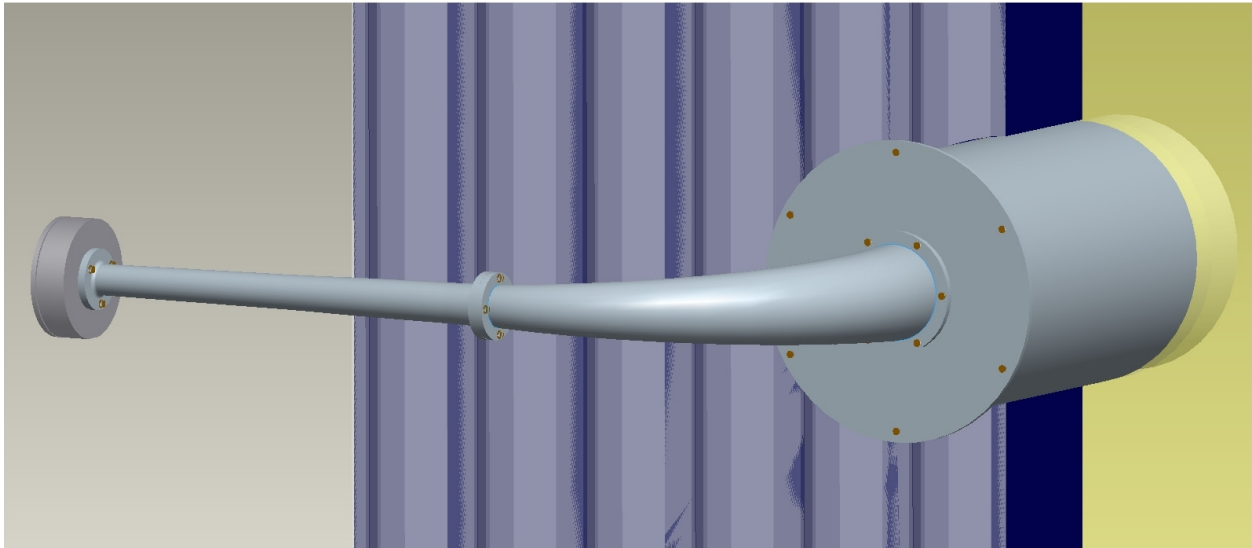

1. Cut a 16.25" diameter opening in the application surface.
2. Place the mounting tube in the proper location as shown in the picture and tack weld in place. The mounting ring should be placed on the mounting surface with holes located in the 12 and 6 o'clock positions. This hole location will ensure the inlet to the horn is in the 6 o'clock position when the horn is mounted on a vertical surface.
3. Assemble the B sect., C sect., and mounting flange together with 5/16-18 x 1.5" hex head cap-screws lock washers, and nuts.
4. Attach the mounting flange to the mounting tube with 5/16-18 x 1" hex head cap-screws lock washers, and nuts.
5. Seal weld the remainder of mounting tube to the application surface.
6. Attach the A sect. and sound generator to the B sect. with 5/16-18 x 1.5" hex head cap-screws lock washers, and nuts.
7. Connect the air supply from the solenoid valve to the sound generator.

Section 6: ACS Piping Installation Diagrams

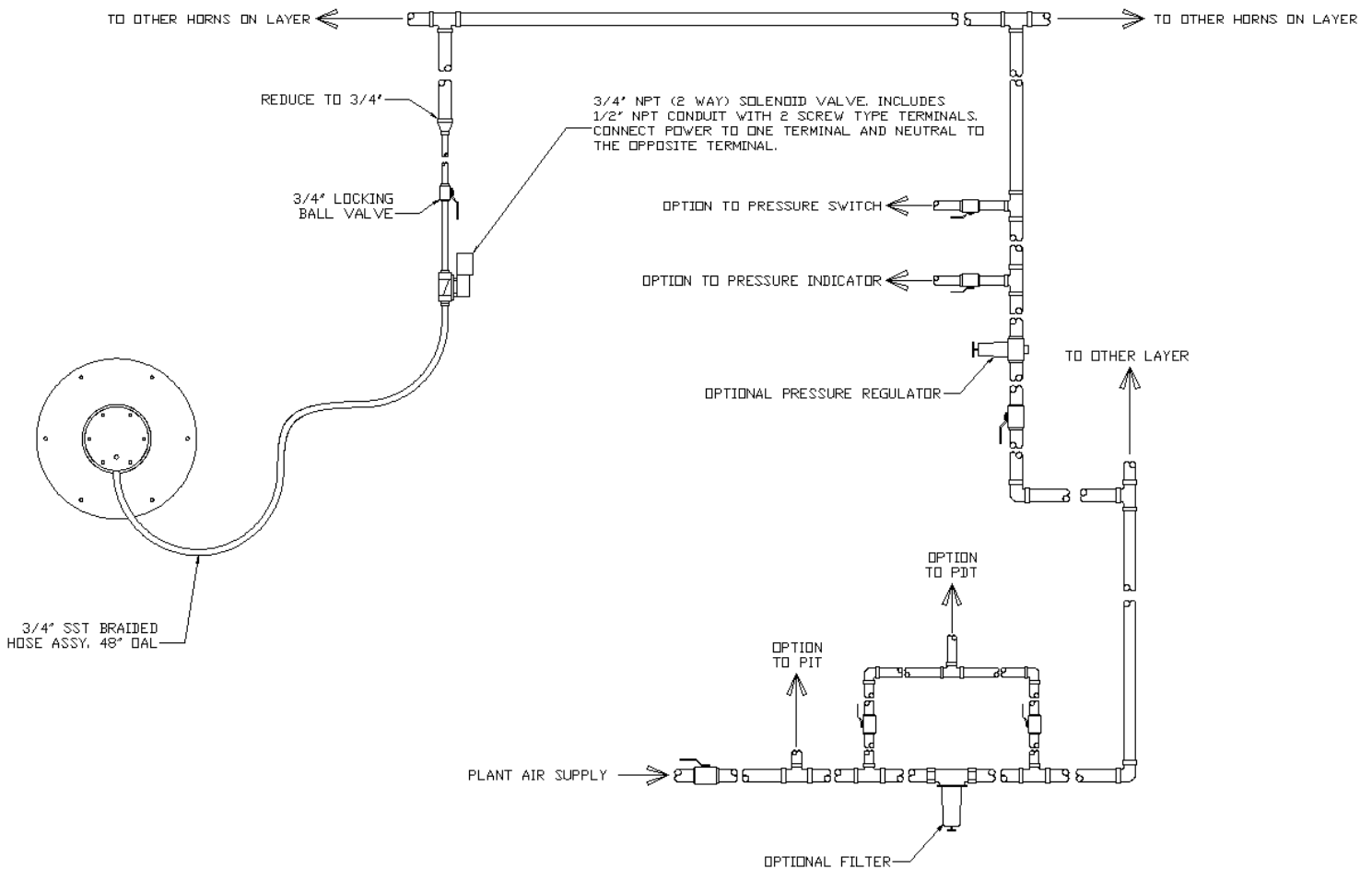

1. A 1" or greater supply line is recommended in order to build reservoir without having to install an accumulator tank. On larger applications where multiple horns are installed an accumulator tank is recommended.
2. The line will require being reduced down to a 3/4" locking ball valve.
3. From the ball valve a 3/4" line to the solenoid valve should be plumbed to within 2-3 feet of the horn.
4. A stainless steel braided hose should be connected from the solenoid valve to the horn.
5. It is also optional to install an in-line air filter and regulator. These can be supplied by ACS if needed.
6. An outlet line is not required or recommended unless it is required to vent the exhaust through a pollution control medium of some sort where toxic exhaust poses an EPA concern.

Section 7: Solenoid Valves

At ACS we offer (2) different solenoid valve options.

ACS Part No. AC-909 is an ASCO ¾" valve with a twist lock override but with a J box and a hi-temp coil.

ACS Part No. AC-950 is an ASCO ¾" valve with a twist lock manual override. This is a ¾"NPTF 2 way valve that has an arrow indicating your air inlet. The outlet port would supply the horn during the operating cycle. This valve is recommended in non filtered applications as it performs best in those conditions.

Section 8: Controls

The sequencing of the acoustic horns can be controlled by a stand alone PLC, automatic timer, or a Plant DCS. The control device would be connected to the solenoid valve that is connected to the inlet of each horn. This control should be capable of providing 5-30 seconds on time and 0-30 minutes off time.

ACS can design and provide a new PLC or automated timer for installations that require them.

Cycling of the horns can vary depending on application. ACS will make the proper recommendations for cycling the units based on the requirements of that application.

Section 9: Repair and Service Parts

At ACS we offer repair and service on all major brands of acoustic horns. We can tear down and assess damage to existing sound generators in order to provide an accurate evaluation of what your system problem is. No work is performed on faulty sound generators until a price is quoted and the customer has agreed upon the price. If it is not feasible to repair the unit then a replacement sound generator will be recommended.

ACS can also retrofit their sound generators to horns manufactured by others and in some cases they will bolt right up to existing units.

The recommended number of spares would depend on the number of horns in service. Typically a 10% rule is applied in multiple horn installations.

Section 10: Maintenance

ACS's acoustic horn has only one moving part the titanium diaphragm. Therefore maintenance and service to the horns are very minimal. The diaphragm life could be from 24 months up to 72 months depending on the application and cycling frequency.

ACS recommends that the following items be checked periodically:

1. Inspect the diaphragm and sound generator for wear every 24 months to insure that the horn is operating at its peak efficiency. Please contact ACS for critical dimensions and tolerances to be inspected. If the diaphragm needs replacing make sure you also replace the gasket with a new one.
2. Check the air pressure and the supply annually.
3. Check the solenoid valves for operation and leakage and replace accordingly.
4. Make sure the exhaust on the cover plate remains unrestricted

Replacement parts and repairs are available from ACS. If you need spare parts or have questions concerning maintenance, please contact us at (256) 820-8427.

Section 11: General Troubleshooting Diagrams

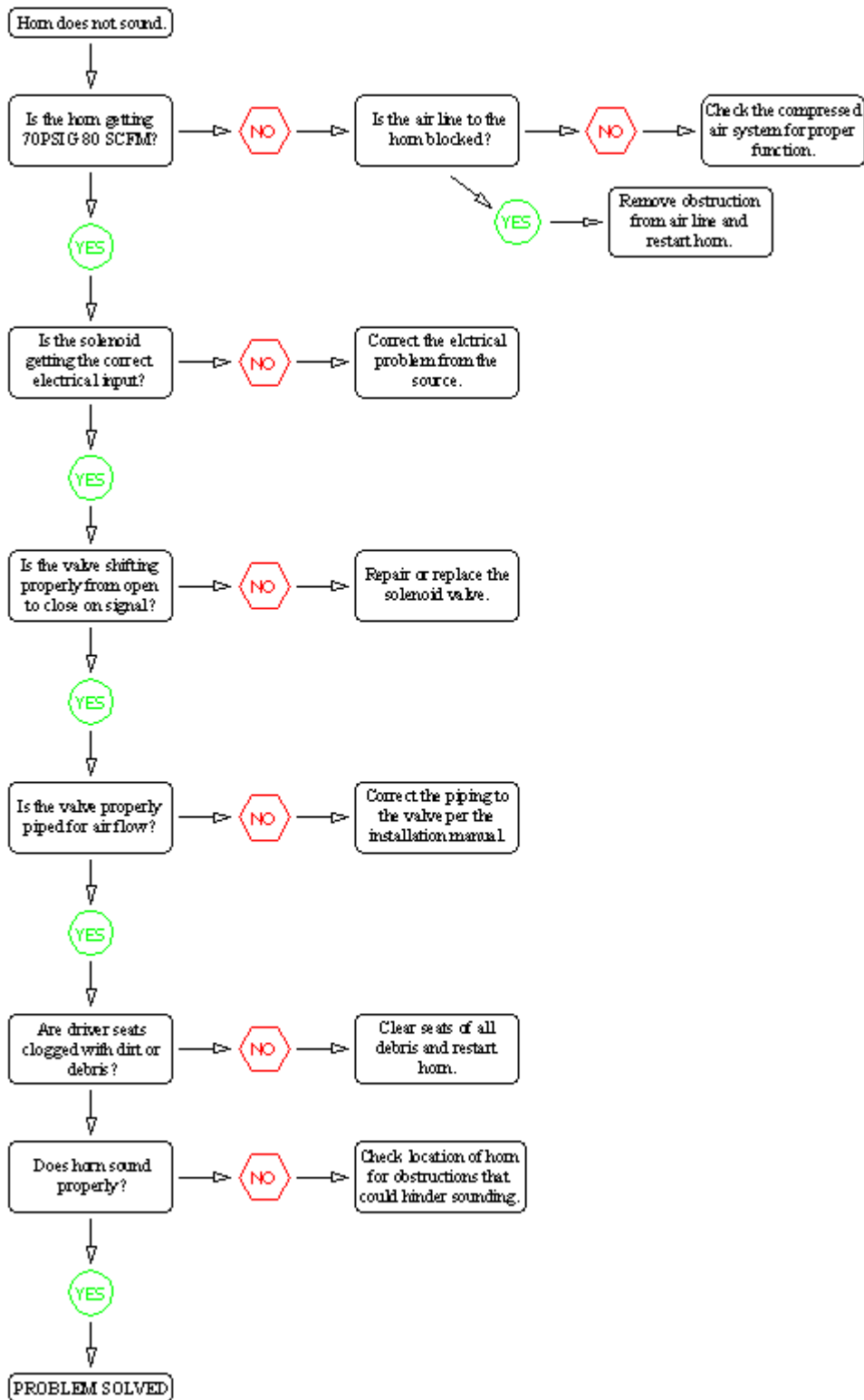

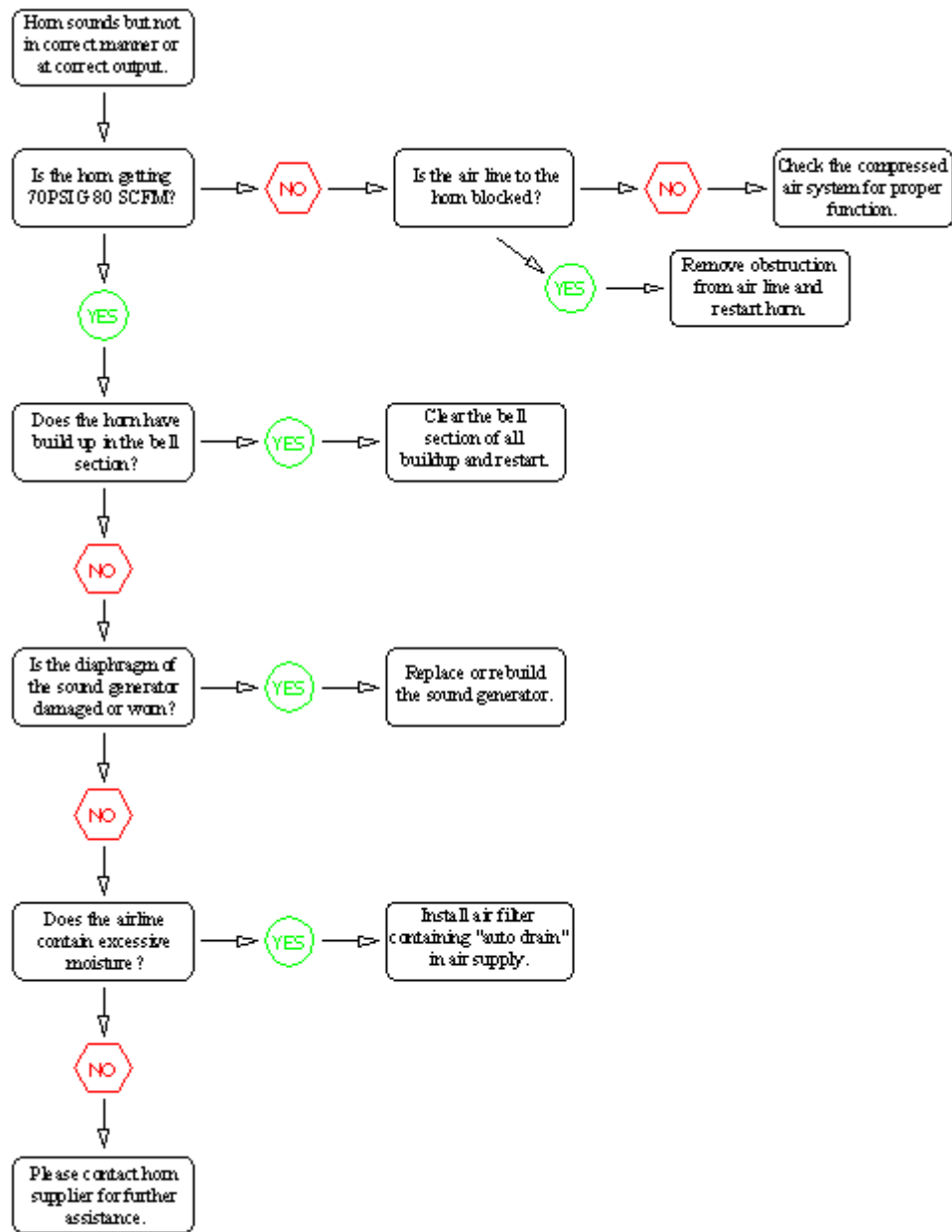

Section 12: Frequently Asked Questions

1. If my air supply is over the recommended 70-90psi do I need to regulate my air?

Answer: Even though the horn will operate at higher pressures it would be best to regulate the air to the recommended pressure requirements.

2. If the horn cannot be located exactly where it is recommended due to an obstruction is it o.k. to adjust location?

Answer: Sonic horn placement is not an exact science and therefore adjustments to location are sometimes required to install. Plus or minus 2 feet in any direction will not typically effect the horns in a detrimental manner, so it is o.k. to adjust location.

3. Can we trim the horn to decrease the diameter in order to install for instance in a soot blower opening?

Answer: Even though the horn is designed to a certain length and diameter for performance purposes, it is sometimes necessary to modify the length in order to get it installed. It is better to modify and install than not to install at all.

4. Should I install an accumulator tank?

Answer: This is dependent on your plants air supply. If you are air limited then an accumulator tank is a good option to remedy potential air supply issues.

5. Do I need to install an air filtering system?

Answer: The horns will operate even if you have marginal air quality, but in most applications it is a good idea to filter the air supply because moisture and dirt can cause detrimental problems to the application but not so much the operation of the horn.

6. What temperature range determines when you go to a SST bell?

Answer: We typically provide a SST bell section once the temperature of the application exceeds 800 degrees Fahrenheit.

7. Do I need to put a street el or some other type fitting in the 1/4" NPT outlet on the cover plate of the horn?

Answer: This opening is strictly an exhaust port and there is no need to put any fitting in it unless there is a potential for rainwater getting into it. In this case we would recommend installing some type of bonnet over the sound generator or installing a street el.

Section 13: Safety Precautions

The following Safety precautions must be followed when working around acoustic horns. Any personnel working in areas where horns exist must be made aware of these precautions.

- Never enter a compartment or confined space area containing acoustic horns without turning off the air supply and de-energizing the solenoid valves electrically.
- Always make sure to lock open the access door or opening to the compartment
- Pay close attention to the warning sign attached to each sonic horn.
- Always wear adequate hearing protection.
- Obtain permission from a supervisor before performing any work on an acoustic horn.
- Notify personnel that acoustic horns producing high intensity sound waves are present in areas that they will be performing work.