

AC-75 Mounting Tube Installation

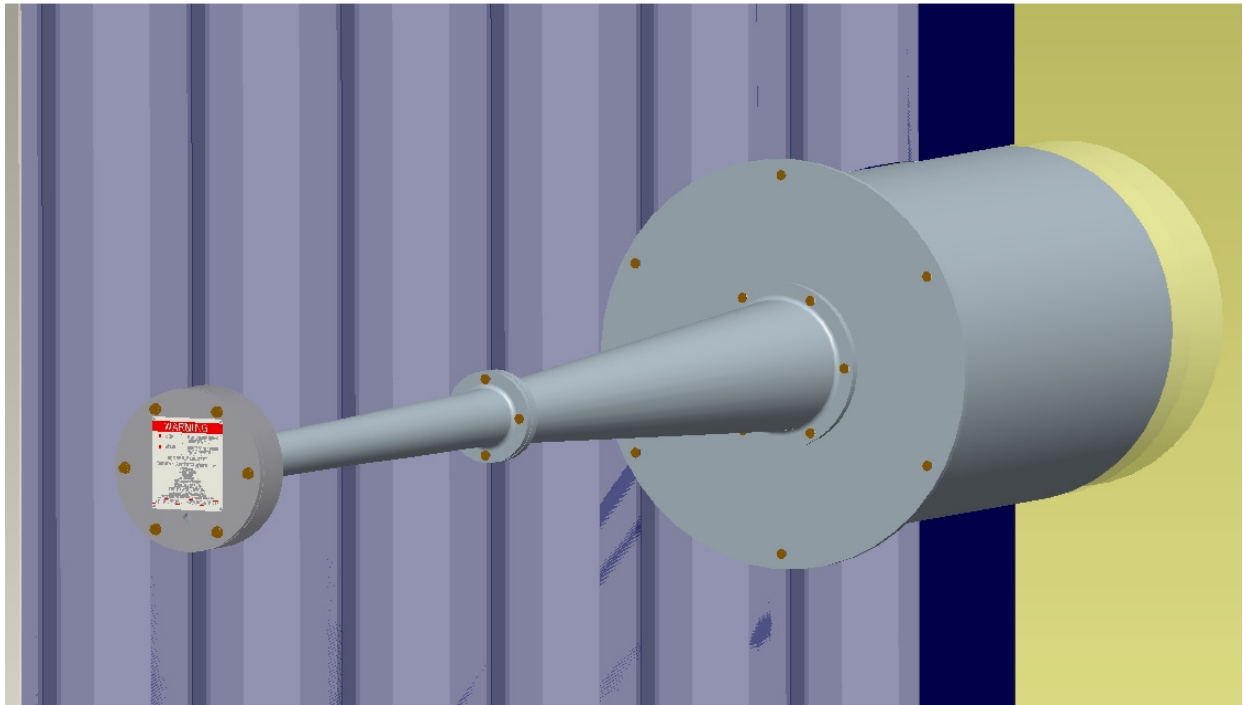

1. Cut a 16.25" diameter opening in the application surface.
2. Place the mounting tube in the proper location as shown in the picture and tack weld in place. The mounting ring should be placed on the mounting surface with holes located in the 12 and 6 o'clock positions. This hole location will ensure the inlet to the horn is in the 6 o'clock position when the horn is mounted on a vertical surface.
3. Assemble the B sect., C sect., and mounting flange together with 5/16-18 x 1.5" hex head cap-screws lock washers, and nuts.
4. Attach the mounting flange to the mounting tube with 5/16-18 x 1" hex head cap-screws lock washers, and nuts.
5. Seal weld the remainder of mounting tube to the application surface.
6. Attach the A sect. and sound generator to the B sect. with 5/16-18 x 1.5" hex head cap-screws lock washers, and nuts.
7. Connect the air supply from the solenoid valve to the sound generator.